

Test Method for Calculating the Energy Efficiency of Single-Voltage External Ac-Dc and Ac-Ac Power Supplies

Chris Calwell, Suzanne Foster, and Travis Reeder, Ecos Consulting
Arshad Mansoor, Power Electronics Application Center (EPRI-PEAC)

August 11, 2004

Funded by the Public Interest Energy Research (PIER) program
California Energy Commission

1. Scope

This document specifies a test method for calculating the energy efficiency of *single-voltage external ac-dc and ac-ac power supplies, herein referred to collectively as “power supplies.”* Power supplies are designed to convert line voltage ac into the low voltage output (either ac or dc) typically required by laptop computers, cordless and cellular phones, portable stereos, etc. *External* power supplies are contained in a separate housing from the product they are powering. These external power supplies are often referred to as “ac adapters.”

A *single voltage* power supply provides one dc or ac output that is either at a fixed voltage or user selectable through a selector switch. Power supplies with multiple, simultaneous output voltages, whether internal or external, are beyond the scope of this document. Dc-dc voltage conversion equipment such as dc-dc converters are not included in the scope of this document, except to the extent that such circuitry may be found within a power supply.

The purpose of this test procedure is to establish a standardized method that can be used worldwide to measure the efficiency of single voltage external ac-dc and ac-ac power supplies across a full range of load conditions. Its intent is not to replace IEC 62301, which focuses closely on the measurement of standby power, but to augment and extend it downward to the measurement of no load conditions and upward to the measurement of active mode conditions. Likewise, its intent is not to replace IEEE 1515-2000, but to add specificity regarding loading conditions and reporting requirements. A number of governments around the world intend to use this test procedure to assess and compare the efficiency of power supplies.

2. References

The following list includes documents used and/or referenced in the development of this proposed test specification.

- I. IEEE Std 1515-2000, IEEE Recommended Practice for Electronic Power Subsystems: Parameter Definitions, Test Conditions, and Test Methods
- II. IEEE Std 519-1992, IEEE Recommended Practices and Requirements for Harmonic Control in Electrical Power Systems
- III. IEC 62301 Ed 1: Measurement of Standby Power
- IV. IEC 60050 International Electrotechnical Vocabulary - Electrical and electronic measurements and measuring instruments
- V. IEEE 100: The Authoritative Dictionary of IEEE Standards Terms

3. Definitions

For the purpose of this document the following definitions apply. Terms defined in IEC 60050 and IEEE 100 also apply.

a. Active Mode

Active mode refers to a condition in which the input of a power supply is connected to line voltage ac and the output is connected to a dc or ac load drawing a fraction of the power supply's nameplate power output greater than zero.

b. Active Mode Efficiency

Active mode efficiency is the ratio, expressed as a percentage, of the total real output power (dc or ac) produced by a power supply to the real input power (ac) required to produce it. See IEEE 1515-2000, 4.3.1.1.

c. No Load

In this document, *no load* refers to a condition in which the input of a power supply is connected to an ac source consistent with the power supply's nameplate ac input voltage, but the output is not connected to a product or any other load.

d. No Load Power

No load *efficiency* would by definition be 0 when calculated on a percentage basis (see 3b above). In this document, *no load power* is defined as the wattage of real power (ac) consumed by a power supply operating in the no load condition.

e. UUT

UUT is an acronym for "unit under test," which in this case refers to the power supply sample being tested.

f. Ambient Temperature

Ambient temperature is the temperature of the ambient air immediately surrounding the UUT.

g. Power Factor (True)

The *true power factor* is the ratio of the active, or real, power (P) consumed in watts to the apparent power (S), drawn in volt-amperes (VA).

$$PF = \frac{P}{S}$$

This definition of power factor includes the effect of both distortion and displacement.

h. Total Harmonic Distortion (THD)

THD is the ratio, expressed as a percent, of the rms value of an ac signal after the fundamental component is removed to the rms value of the fundamental component. *THD* of current is defined as:

$$THD_I = \frac{\sqrt{I_2^2 + I_3^2 + I_4^2 + I_5^2 \dots + I_{13}^2}}{I_1}$$

where I_{13} = rms value of 13th harmonic of the current signal.

i. Apparent Power (S)

The total or *apparent power* (S) is the product of rms voltage and rms current (VA).

j. Instantaneous Power

The product of the instantaneous voltage and instantaneous current at a port (the terminal pair of a load).

k. Active Power (P)

The rms value, taken over one period, of the instantaneous power. Most measuring instruments average active power over a number of periods (ac cycles); readings from such instruments are equally valid for this measurement.

l. Nameplate Input Voltage

Nameplate input voltage is the appropriate ac input voltage of the power supply as specified by the manufacturer on the label on the housing of the power supply. This is often expressed as a range, such as 100 to 240 V.

m. Nameplate Input Frequency

Nameplate input frequency is the appropriate ac input frequency of the power supply as specified by the manufacturer on the label on the housing of the power supply. Many power supplies are labeled to operate on more than one input frequency.

n. Nameplate Output Voltage

Nameplate output voltage is the voltage output of the power supply as specified by the manufacturer on the label on the housing of the power supply (either dc or ac). Because unregulated and regulated power supplies both exhibit some voltage deviation from nameplate output voltage when supplying current, actual output voltage is likely to differ from nameplate voltage at certain current outputs.

o. Nameplate Output Current

Nameplate output current is the current output of the power supply as specified by the manufacturer on the label on the housing of the power supply. Loading conditions for the power supply are determined by multiplying nameplate output current by 100%, 75%, 50%, 25%, and 0% respectively.

4. General Conditions for Measurement

a. General

Unless otherwise specified, measurements shall be made under test conditions and with equipment specified below.

b. Measuring Equipment

Power measurements shall be made with a suitably calibrated voltmeter and ammeter, or power analyzer. As is specified in IEC 62301, measurements of active power of 0.5 W or greater shall be made with an uncertainty of $\leq 2\%$. Measurements of active power of less than 0.5 W shall be made with an uncertainty of ≤ 0.01 W. The power measurement instrument shall have a resolution of 0.01W or better for active power. Measurements of voltage and current shall be made with an uncertainty of $\leq 2\%$.

c. Test Room

As is specified in IEC 62301, the tests shall be carried out in a room that has an air speed close to the UUT of ≤ 0.5 m/s, and the ambient temperature shall be maintained at $23^{\circ}\text{C} \pm 5^{\circ}\text{C}$ throughout the test. There shall be no intentional cooling of the UUT by use of separately powered fans, air conditioners, or heat sinks. The UUT shall be tested on a thermally non-conductive surface. Products intended for outdoor use may be tested at additional temperatures, provided those are in addition to the conditions specified above and are noted in a separate section on the test report.

d. Test Voltage

An ac reference source shall be used to provide input voltage to the UUT. As is specified in IEC 62301, the input to the UUT shall be the specified voltage $\pm 1\%$ and the specified frequency $\pm 1\%$. The UUT shall be tested at two voltage and frequency combinations: 115 V at 60 Hz and 230 V at 50 Hz if its nameplate input voltage and frequency indicate that it can operate safely under both conditions. If testing at both conditions is not possible, the UUT shall be tested at one of the above voltage and frequency combinations that is closest to its nameplate input voltage and frequency. If voltage and/or frequency ranges are not specified by the manufacturer (or the nameplate value is unclear), the UUT shall not be tested.

e. Input ac reference source

The input voltage source shall be capable of delivering at least 10 times the nameplate input power of the UUT (as is specified in IEEE 1515-2000). Regardless of the ac source type, the THD of the supply voltage when supplying the UUT in the specified mode shall not exceed 2%, up to and including the 13th harmonic (as specified in IEC 62301). The

peak value of the test voltage shall be within 1.34 and 1.49 times its rms value (as specified in IEC 62301).

f. Test leads

All leads used in the test set-up should be of large gauge and short length in order to avoid the introduction of errors in the testing process. For further guidance, see Table B.2, “Commonly used values for wire gages and related voltage drops” in IEEE 1515-2000.

5. Measurement Approach

a. Preparing UUT for Test

Any built-in switch in the UUT controlling power flow to the ac input shall be in the “on” position for this measurement, and the existence of such a switch shall be noted in the final test report.

Power supplies that are packaged for consumer use to power a product must be tested with the output cord supplied by the manufacturer. There are two options for connecting metering equipment to the output of this type of power supply: cut the cord immediately adjacent to the output connector, or attach leads and measure the efficiency from the output connector itself. If the power supply is attached directly to the product that it is powering, cut the cord immediately adjacent to the powered product and connect output measurement probes at that point. If the product has more than two output wires, the tests should be conducted on the two output wires that supply the output power. The other output wires (sometimes used for battery monitoring) should be left electrically disconnected.

It is also possible to utilize this procedure to test the efficiency of a bare circuit board power supply prior to its incorporation into a finished housing and the attachment of its dc output cord. For example, a power supply manufacturer or component manufacturer may wish to assess the efficiency of a design that it intends to provide to an OEM for incorporation into a finished external power supply. However, the efficiency of the bare circuit board power supply may not be used to characterize the efficiency of the final product (once enclosed in a case and fitted with an output cord). Power supplies must be tested in their final, completed configuration in order to represent their measured efficiency on product labels or specification sheets.

b. Load Conditions

All single voltage external power supplies have a nameplate output current, as shown in Figure 1. This is the value used to determine the four active mode load conditions and the no load condition required by this test procedure. The UUT shall be tested at the following load conditions:

Table 1 – Load Conditions for UUT

Percentage of Nameplate Output Current	
Load Condition 1	100 % ± 2%
Load Condition 2	75% ± 2%
Load Condition 3	50% ± 2%
Load Condition 4	25% ± 2%
Load Condition 5	0%

The 2% allowance is of nameplate output current, not of the calculated current value. For example, a UUT at Load Condition 3 may be tested in a range from 48% to 52% of rated output current.

Additional load conditions may be selected at the technician’s discretion, as described in IEEE 1515-2000, but are not required by this test procedure.

Figure 1– Example of Ac-Dc Power Supply Nameplate Output Voltage and Current



c. Loading Guideline

In order to load the power supply to produce all four active mode load conditions, a set of variable resistive or electronic loads shall be used. While these loads may have different characteristics than the electronic loads power supplies are intended to power, they provide standardized and readily repeatable references for testing and product comparison.

Note that resistive loads need not be measured precisely with an ohmmeter. A variable resistor is simply adjusted to the point where the ammeter confirms that the desired percentage of nameplate output current is flowing. Figure 2 shows a simplified schematic of an external power supply test set-up using variable resistance as the load. For

electronic loads, the desired output current should be adjusted in constant current (CC) mode rather than adjusting the required output power in constant power (CP) mode.

Figure 2 - Generic Test Set-up Using a Variable Resistance Load

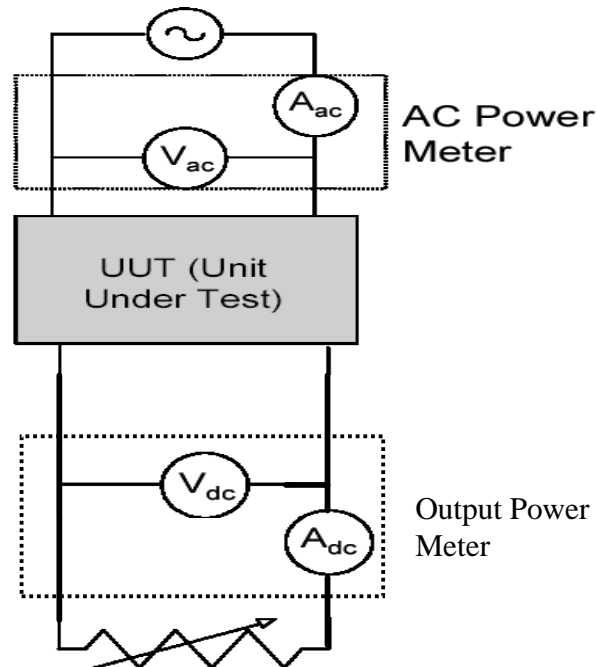

d. Testing Sequence

As noted in IEC 62301, instantaneous measurements are appropriate when power readings are stable in a particular load condition. The UUT shall be operated at 100% of nameplate current output for at least 30 minutes immediately prior to conducting efficiency measurements.

After this warm-up period, the technician shall monitor ac input power for a period of 5 minutes to assess the stability of the UUT. If the power level does not drift by more than 5% from the maximum value observed, the UUT can be considered stable and the measurements can be recorded at the end of the 5 minute period. Subsequent load conditions (see below) can then be measured under the same 5 minute stability guidelines. Note that only one warm-up period of 30 minutes is required for each UUT at the beginning of the test procedure.

If ac input power is not stable over a 5 minute period, the technician shall follow the guidelines established by IEC 62301 for measuring average power or accumulated energy over time for both ac input and dc output.

Efficiency measurements shall be conducted in sequence from Load Condition 1 to Load Condition 5 as indicated in Table 1 above. If testing of additional, optional load

conditions is desired, that testing should be conducted in accordance with this test procedure and subsequent to completing the sequence described above.

e. Efficiency Calculation

Efficiency shall be calculated by dividing the UUT’s measured active output power at a given load condition by the active ac input power measured at that load condition. Average efficiency shall also be calculated and reported as the arithmetic mean of the efficiency values calculated at Test Conditions 1, 2, 3, and 4 in Table 1. This is a simple arithmetic average of active mode efficiency values, and is not intended to represent weighted average efficiency, which would vary according to the duty cycle of the product powered by the UUT.

f. Power Consumption Calculation

Power consumption of the UUT at each Load Condition 1 – 4 is the difference between the active output power (W) at that Load Condition and the ac active input power (W) at that Load Condition. The power consumption of Load Condition 5 (no load) is equal to the ac active input power (W) at that Load Condition.

6. Test Report

The following information shall be reported once for each UUT: UUT manufacturer, UUT model number, UUT dc cord length (± 1 cm), whether a built-in switch is present on the UUT, product powered by the UUT if known, photo of UUT that a) clearly shows nameplate information and b) displays the size of the entire UUT with a centimeter rule for scale, UUT country of manufacture, name of test lab, name of technician performing the test, ambient temperature immediately surrounding the UUT (± 1 °C), date and location of test, and a description of test equipment used with most recent calibration date.

The key data (measured and calculated) to report for each input voltage and frequency combination at which was test conducted are found in Table 2 below.

Table 2 – Required Reported Data (Measured and Calculated)

Reported Quantity	Description
Rms Output Current (mA)	Measured at Load Conditions 1 – 4
Rms Output Voltage (V)	
Active Output Power (W)	
Rms Input Voltage (V)	Measured at Load Conditions 1 – 5
Rms Input Power (W)	
Total Harmonic Distortion (THD)	
True Power Factor	
Power Consumed by UUT (W)	Calculated at Load Condition 1 – 4, Measured at Load Condition 5
Efficiency	Calculated at Load Conditions 1 – 4
Average Efficiency	Arithmetic Average of Efficiency at Load Conditions 1 – 4

The test data are most usable and readily compared to other results if also presented in graphical form, as shown in the sample test report in Annex A. Note that the efficiency curve shown in Annex A is similar in format to that shown in IEEE 1515-2000, 4.3.1.2, Figure 10.

The “Input vs. Output Power” chart in Annex A provides an additional, useful means of conveying a power supply’s relative efficiency that includes ac active input power and active output power at 100%, 75%, 50%, 25%, and 0% of nameplate current output on a single chart. The shaded area between the input and output power curves will be quite small with highly efficient power supplies. Note also that the output power curve will be close to a straight line in a regulated power supply, but may deviate from a straight line significantly in unregulated units where voltage is not stable across a range of load conditions.

Annex A

(Final report form generated by Microsoft Access and provided in separate document)

Ac-Dc Single Output Voltage External Power Supply Test Report

Manufacturer Name *Power Integrations*
Model *EP16F*
Product Powered (if known) *(Evaluation Charger)*

Country of Manufacturer *Korea*
Integral Input Power Switch *Not Present*
Dc Output Cord Length (cm) *175*



Nameplate Specifications	Input	Output
Voltage (V)	85-265	6
Current (mA)		500
Power (W)		2.8
Frequency (Hz)	50/60	

Lab Information

Test Laboratory Ecos Consulting
Street Address 801 Florida Rd.
 Suite 11
City Durango
State/Province CO
Postal Code 81301-
Country U.S.A.

Date Measured 3/30/2004
Ambient Temp. °C 24

Meter Information

Make/Model	Measurement	Calibration Date
Yokagawa	No Load	5/ 6/2003
Voltec PM300	Active Output an	8/ 1/2003

Technician(s)

Name	Email
Travis Reeder	treeder@ecosconsulting.com
Eric McClusky	emcllusky@ecosconsulting.com

Measured and Calculated Data at 115 V 60 Hz

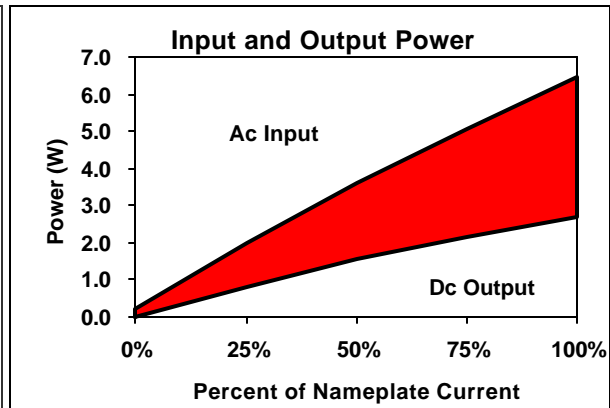
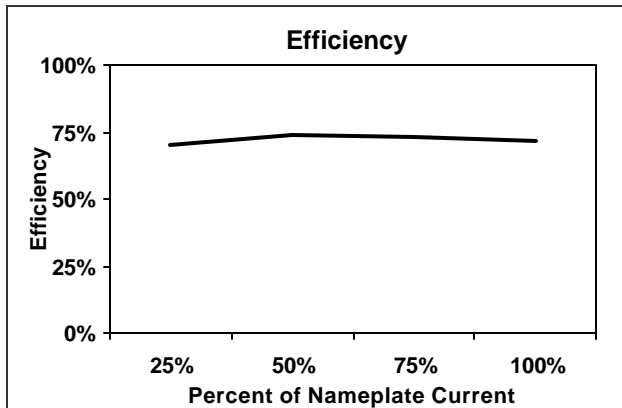

	No Load	Active Power Values				
Percent of Nameplate Current	0%	25%	50%	75%	100%	Average
Dc Output Current (mA)		125	250	374	507	
Dc Output Voltage (V)		6.6	6.2	5.7	6.6	
Dc Output Power (W)		0.83	1.54	2.14	2.7	
Ac Input Voltage (V)	115	115	115	115	115	
Ac Input Power (W)	0.21	1.18	2.09	2.94	3.75	
Total Harmonic Distortion (THD)		213.6%	191.7%	172.7%	160.8%	184.7%
True Power Factor (W/VA)		0.41	0.46	0.49	0.51	0.47
Ac Input Frequency	60	60	60	60	60	60
Power Consumed by UUT (W)	0.21	0.35	0.55	0.80	1.05	
Efficiency		70.3%	73.7%	72.8%	72.0%	72.2%

Measured and Calculated Data at 230 V 50 Hz

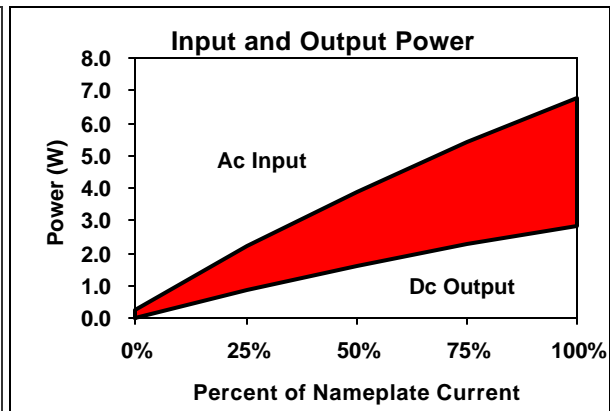
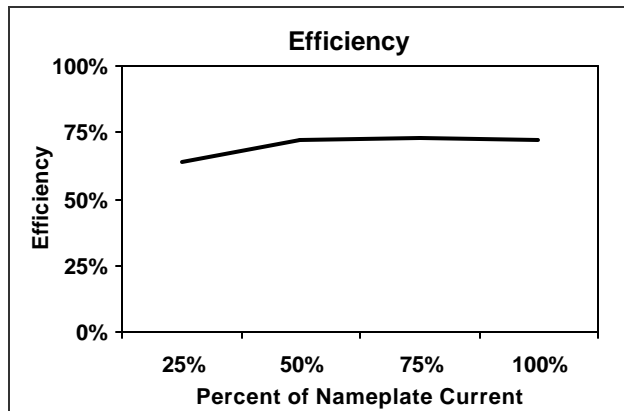

	No Load	Active Power Values				
Percent of Nameplate Current	0%	25%	50%	75%	100%	Average
Dc Output Current (mA)		125	250	374	500	
Dc Output Voltage (V)		6.9	6.5	6	5.7	
Dc Output Power (W)		0.86	1.62	2.27	2.83	
Ac Input Voltage (V)	230	230	230	230	230	
Ac Input Power (W)	0.25	1.35	2.25	3.12	3.91	
Total Harmonic Distortion (THD)		271.0%	256.2%	246.6%	233.1%	251.7%
True Power Factor (W/VA)		0.35	0.36	0.37	0.39	0.37
Ac Input Frequency	50	50	50	50	50	50
Power Consumed by UUT (W)	0.25	0.49	0.63	0.85	1.08	
Efficiency		63.7%	72.0%	72.8%	72.4%	70.2%