

# **ENERGY STAR<sup>®</sup> Telephony: Draft Test Procedure Overview**

**Stakeholder Webinar**

**October 4, 2011**

**U.S. Department of Energy**

**U.S. Environmental Protection Agency**

# Agenda



- 1 Introduction
- 2 Specification Revision
- 3 Review of Draft Test Method
- 4 Questions for Stakeholders
- 5 Next Steps

# Introduction



- 1 Introduction
- 2 Specification Revision
- 3 Review of Draft Test Method
- 4 Questions for Stakeholders
- 5 Next Steps

# Webinar Details

- Audio provided via conference call in:
  - Call in: +1.877.423.6338 (in the US)  
+1.571.281.2578 (international)
  - Code: 456-417
  - Please keep phone lines on mute unless speaking
  - Press **\*6 (star, then 6)** to mute and un-mute your line
- Webinar materials will be available online shortly
  - Go to: [www.energystar.gov/revisedspecs](http://www.energystar.gov/revisedspecs)
  - Click on Telephony



# ENERGY STAR Program Overview



- ENERGY STAR is a public-private partnership program dedicated to helping individuals and businesses protect the environment through superior energy efficiency



- Program covers buildings, homes and products
- More than 60 ENERGY STAR product categories are available in over 40,000 retail storefronts in the US and Puerto Rico and are actively promoted by over 700 utilities programs
- The brand is internationally recognized and implemented

# ENERGY STAR Influence

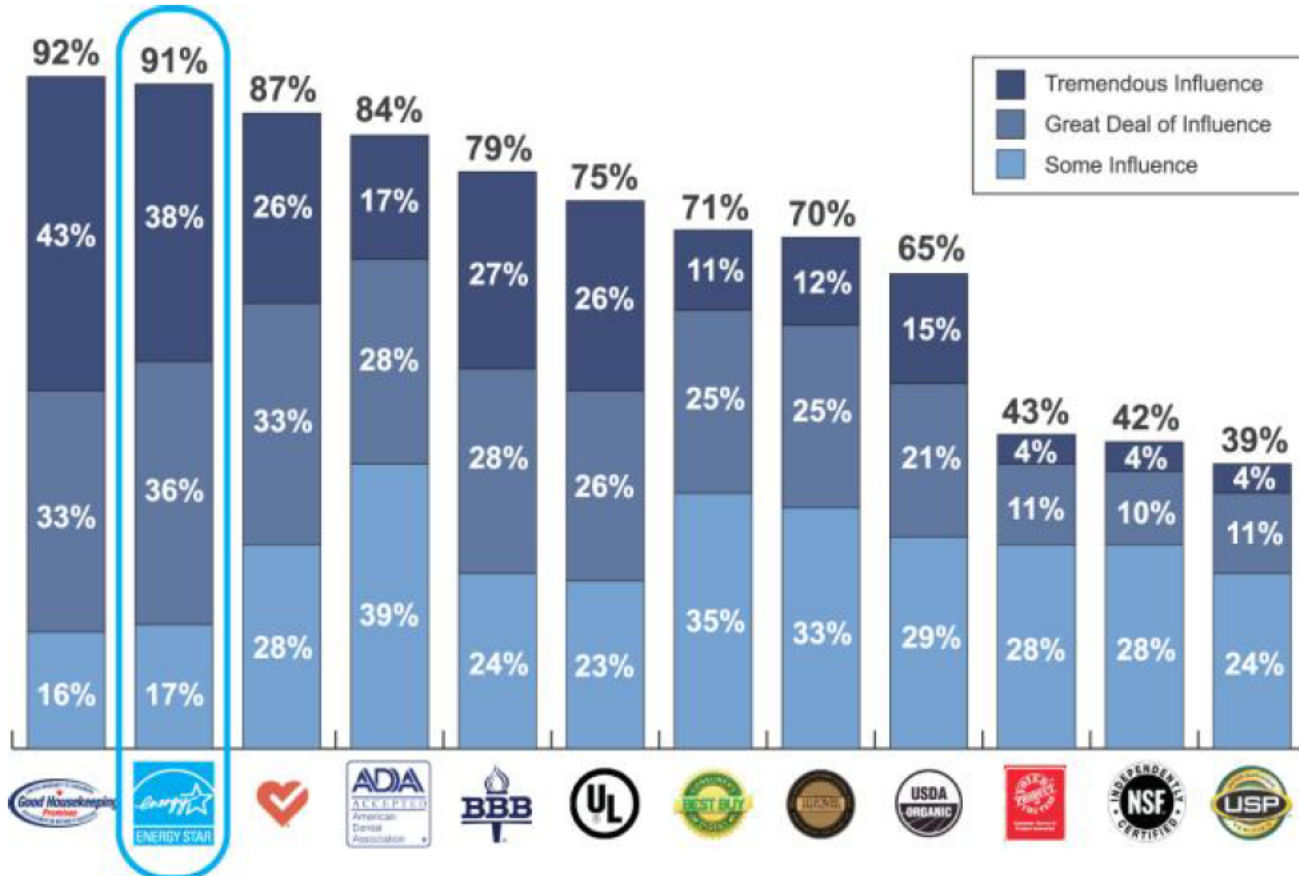

Source: Fairfield Research, July 2009

The ENERGY STAR mark ranks among the highest level of influence on product purchase among all consumer emblems, similar in ranking to the *Good Housekeeping Seal*.

# ENERGY STAR Program Roles



- U.S. Environmental Protection Agency
  - Lead revision of telephony specification
  - EPA Lead: Katharine Kaplan, EPA
  - Support: ICF International
- U.S. Department of Energy
  - Develop and validate telephony test method
  - DOE Lead: Bryan Berringer, DOE
  - Support: Navigant Consulting

# Specification Revision



- 1 Introduction
- 2 Specification Revision**
- 3 Review of Draft Test Method
- 4 Questions for Stakeholders
- 5 Next Steps

# Specification Development Principles



- Guiding Principles of Specification Development
  - Cost-effective efficiency
  - Performance maintained or enhanced
  - Significant energy savings potential
  - Efficiency improvements are achievable with non-proprietary technology
  - Product differentiation and testing are feasible
  - Labeling can be effective in the market



# Specification Development Cycle



# ENERGY STAR Telephony Program



- Telephony products first qualified for the ENERGY STAR label in 2002—focus on standby requirements
- Version 2.0 specification effective in 2006
  - Version 2.1 released in 2008 clarified requirements for external power supplies
  - Version 2.2 released in 2010 clarified testing requirements to permit Third-party Certification
- ENERGY STAR is launching the development of the Version 3.0 telephony specification

# Currently Covered Products



- Current covered products include:
  - Cordless phones,
  - Answering machines,
  - Additional handsets, and
  - Combination units



- High market penetration of existing ENERGY STAR qualified telephony products
  - 60% for cordless phones
  - 80% for combination units



# Justification for Specification Revision



- EPA seeks to refresh energy efficiency requirements for currently covered products
  - Take into consideration increasing prevalence of additional features, such as color displays, extended range, and connectivity with home broadband networks
  - Revision of currently covered product requirements may save over 90 million kWh a year nationwide
- EPA also seeks to expand the scope to corded phones and VoIP phones

# Additions to the Scope



## Corded Phones

- Same features as cordless:
  - EPS
  - Answering Device
  - Radio Transceiver



## Voice-over-Internet-Protocol Phones

- Phone that implements VoIP
- Sound converted into IP data packets for network transmission
- Back-end system (servers, switches) excluded from scope

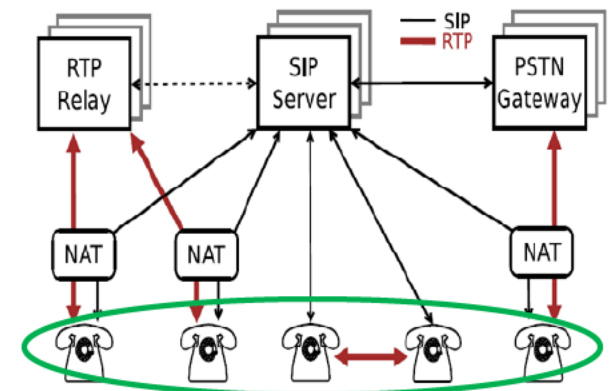

Client-server ITSP architecture  
Source: Baset and Schulzrinne. *Energy Efficiency of Voice-over-IP Systems*. Columbia University 2010



# VoIP Phone Savings Opportunity

- EPA interested in energy savings potential in the growing market for VoIP phones
  - Always-on VoIP hardphones consume 2–6 W  
(Source: Baset and Schulzrinne. *Energy Efficiency of Voice-over-IP Systems*. Columbia University 2010)
  - Savings up to 60% achievable within a product class  
(Source: Tolly Enterprises, LLC, 2010)
  - Hardphones can consume 80% of all the electricity in the VoIP system (Source: Tolly Enterprises, LLC, 2010)
  - IP phone shipments to business and consumers expected to exceed 40 million units in 2015 (Source: In-Stat)

# VoIP Improvement Potential

- Energy saving opportunities include:
  - Energy-efficient Ethernet (EEE)
  - Energy-efficient electronics design
  - Use of low power modes
  - Use of energy saving SIP proxy to allow main part of phone to sleep

Based in part on Baset and Schulzrinne. *Energy Efficiency of Voice-over-IP Systems*. Columbia University 2010

# Summary of Proposed Scope



		Non-VoIP	VoIP
<b>Cordless</b>		<b>Currently Covered</b>	<b>Under Consideration:</b> - Power over Ethernet (PoE) & AC-powered - With & Without Computer Connectivity
<b>Corded</b>	<i>w/ EPS</i>	<b>Under Consideration</b>	
	<i>w/o EPS</i>	<b>Not under Consideration</b>	
<b>Mobile (cellular)</b>		(Proposed inclusion under ENERGY STAR Battery Charging Systems Program, specification currently under revision.)	

Key:

<b>Currently Covered</b>	<b>Under Consideration</b>	<b>Not under Consideration</b>
--------------------------	----------------------------	--------------------------------

# Questions for Stakeholders



## Specification Scope and Savings Opportunities

Are there potential efficiency gains in the corded phone segment? Are corded and cordless models typically bundled together?

Which types of VoIP phones should be considered in the specification? Should the focus be on business and consumer hard phones intended for 24/7 operation?

Are the products included in the proposed scope characterized properly? Are there certain product segments becoming less relevant in the market?

# Review of Draft Test Method



- 1 Introduction
- 2 Specification Revision
- 3 Review of Draft Test Method**
- 4 Questions for Stakeholders
- 5 Next Steps

# Review of Draft Test Method: Proposed Updates from Version 2.2



- Includes cordless phone “standby” test from Version 2.2
- UUT setup updated to be consistent with *IEC 62301, Ed. 2.0, “Household Electrical Appliances – Measurement of Standby Power”*
- Additional instruction provided for VoIP Phones
  - PoE Measurements
  - Setup of Backend System
- New proposed test modes/nomenclature (IEC 62542)
  - Partial On (All products)
  - Idle Mode (VoIP Phones only)
  - Computer Connectivity (Applicable VoIP Phones only)



# Review of Draft Test Method: Setup



**Recognizing the complexity of Telephony infrastructure, the following setup conditions have been proposed to minimize testing burden:**

## General

- Does NOT require connection to the Public Switched Telephone Network (PSTN)
- UUT must be capable of making and receiving calls on the local network (there should be a dial tone or a connection to a VoIP system where calls can be made internally within the VoIP system)

## Voice Over Internet Protocol Phones

- Requires standard VoIP backend system configuration and/or equipment

## Cordless Phones

- In place of a phone line, a Ringdown Simulator may be used

# Review of Draft Test Method: Proposed Measurement Methods



## PoE Measurement Method

- For all PoE capable VoIP Phones
- Intended to isolate phone measurements from network infrastructure
- Derived from the “Direct Meter Reading Method” (*IEC 62301*)
- Requires PoE Power Meter

### PoE Power Meter Requirements

- Measures directly over Ethernet cable (CAT5/5e/6/6a/7)
- Compatible with all PoE modes (A and B)
- Meter is not required to log data (can be recorded by hand; *subject to change based on recently received feedback*)

## Ac Power Measurement Method

- For Cordless Phones and non-PoE capable VoIP Phones

# Review of Draft Test Method: Proposed Measured Modes



## Consistent with proposed IEC 62542 definitions and nomenclature

- Primary Function: Sending/receiving voice data
- Possible Secondary Functions:
  - Waiting for a call
  - Battery Charging (not tested)
  - Powered Display
  - Providing Computer Connectivity
- Possible Tertiary Functions:
  - None in this product class

# Review of Draft Test Method: Proposed Measured Modes



- Partial On Mode (All products)
  - Handset “on the hook”
  - No primary function
  - Possible secondary functions: Powered display
- Idle Mode (VoIP Phones only)
  - Handset “off the hook”
  - No primary function, but ready to initiate
  - Possible secondary functions: Dial tone, powered display
- Partial On w/ Computer Connectivity (VoIP Phones only)
  - Handset “on the hook”
  - Computer connected to network via UUT’s switch port

# Questions for Stakeholders



- 1 Introduction
- 2 Specification Revision
- 3 Review of Draft Test Method
- 4 Questions for Stakeholders**
- 5 Next Steps

# Questions for Stakeholders



## Power Measurement Methods

Are stakeholders familiar with PoE Power Meters that have significantly good accuracy?

Are there other methods for directly (not AC side of injector) measuring power over an Ethernet line? Are these methods accessible to 3<sup>rd</sup> party labs?

Stakeholders are also encouraged to comment on the use of PoE midspans (power injectors) for measuring purposes.

# Questions for Stakeholders



## VoIP Backend System Requirements

There have been comments to suggest that VoIP phone power consumption is heavily influenced by the structure and manufacturer of the backend system as it allows the use of proprietary protocols and/or techniques.

Can a test procedure dictate a default configuration and not impact the testing accuracy?

Would requirements on what infrastructure needs to be in place during testing unduly increase testing burden?

# Questions for Stakeholders



## Idle Mode Testing

Section 7 of the Draft Test Method tests Idle Mode for VoIP Phones, specifying the presence of a dial tone.

The dial tone may not last the duration of the test. After a phone loses a dial tone, does it typically enter a lower power state?

Would an Operation Mode test (using a representative conversation) be more suitable? Would it be needlessly complicated?



# Next Steps



- 1 Introduction
- 2 Specification Revision
- 3 Review of Draft Test Method
- 4 Questions for Stakeholders
- 5 Next Steps

# Written Comments



- In addition to making verbal comments during today's meeting, stakeholders are strongly encouraged to submit written comments and data
- Please send all comments to:  
[telephony@energystar.gov](mailto:telephony@energystar.gov)

## Comment Deadline

Thursday, October 13, 2011

# Anticipated Specification Development Timeline



Milestone	Anticipated Date
Final Test Method Published	December 2011
Data Assembly	Dec. 2011– Feb. 2012
Draft 1 Specification Released	March 2012
Specification Completion	August 2012

# Open Comment

---



- EPA and DOE would now like to open up the line for any additional comments from stakeholders

# Contact Information



## Send Comments to:

[telephony@energystar.gov](mailto:telephony@energystar.gov)

## Other Questions:

Katharine Kaplan, EPA

[Kaplan.Katharine@epa.gov](mailto:Kaplan.Katharine@epa.gov)

Matt Malinowski, ICF

[MMalinowski@icfi.com](mailto:MMalinowski@icfi.com)

Bryan Berringer, DOE

[Bryan.Berringer@ee.doe.gov](mailto:Bryan.Berringer@ee.doe.gov)

Nicholas Imbriglia, Navigant

[Nicholas.Imbriglia@navigant.com](mailto:Nicholas.Imbriglia@navigant.com)

# Thank You



- 1 Introduction
- 2 Specification Revision
- 3 Review of Draft Test Method
- 4 Questions for Stakeholders
- 5 Next Steps